

Hercu-Link™ Electric Chain Hoist

5 to 50 metric ton capacity



Standard features

- Space saving, low headroom, compact design; approximately one third the “envelope” size of comparable wire rope hoists
- True vertical lift
- Continuous duty hoist and trolley motor
- IEEE45 marine grade motors
- Thermal overload protection
- 110 volt control circuit with fused and grounded transformer
- Class ‘F’ insulation on hoist motor
- All popular voltages available; 460-3-60 standard
- Upper and lower limit switches
- NEMA 4 weather resistant control enclosure
- 16mm and 22mm alloy zinc plated load chain. Heat treated and calibrated, 10ft (3 m) of lift standard
- Chain guides
- Alloy steel hooks with safety latches and roller thrust bearings
- Planetary gearing
- Lifting lugs for easy installation
- Automatic multiple disc motor brake
- Manual brake release (for lowering load in event of power loss)
- Trolley rail sweeps (safety lugs)
- Trolley guide rollers are standard on Frame 2 motorized trolley models
- All non-oil bath bearings are regreasable

Options:

- Dual speed motors
- 208, 230, 380, 400, 415, 575 motor voltages
- Longer lifts
- Longer pushbutton cord
- Longer power supply cables
- Galvanized expanded metal chain containers
- Plain, geared, motorized trolley units
- Corrosion resistant marine grade coating system: sandblast to white metal finish and carbozinc primer with a Marine 812 finish
- Trolley bumpers and guide rollers (standard on Frame 2 models)
- Sandblast carbozinc primer
- Electronic overload protection



HE1-020M motorized trolley mount

Hercu-Link specifications

Model no.	Capacity		Head room		Hoist lift speed/min		Hoist lower speed/min		Hoist hp	Chain falls	Trolley speed		Trolley hp	no. of wheels	Wheel loading per wheel		Ship weight	
	lbs	kg	in.	mm	ft	m	ft	m			ft/min	m/min			lbs	kg	lbs	kg
Frame 1 (16 mm chain)																		
HE1-005H	11000	5000	34.44	875	17	5.2	19.1	5.8	7.5	1	–	–	–	–	–	–	685	311
HE1-005M	11000	5000	30.50	775	17	5.2	19.1	5.8	7.5	1	18	5.5	1.5	4	2968	1349	905	411
HE1-010H	22000	10000	41.81	1062	8.5	2.6	9.6	2.9	7.5	2	–	–	–	–	–	–	765	348
HE1-010M	22000	10000	36.94	938	8.5	2.6	9.6	2.9	7.5	2	18	5.5	1.5	4	5755	2616	1105	502
HE1-015H	33000	15000	48.13	1222	5.6	1.7	6.3	1.9	7.5	3	–	–	–	–	–	–	875	398
HE1-015M	33000	15000	41.63	1057	5.6	1.7	6.3	1.9	7.5	3	18	5.5	1.5	4	8558	3890	1315	598
HE1-020H	44000	20000	49.50	1257	4.3	1.3	4.8	1.5	7.5	4	–	–	–	–	–	–	975	443
HE1-020M	44000	20000	41.44	1053	4.3	1.3	4.8	1.5	7.5	4	18	5.5	1.5	4	11332	5151	1425	648
Frame 2 (22 mm chain)																		
HE2-012H	26400	12000	43.88	1114	15	4.6	16	4.9	15	1	–	–	–	–	–	–	965	439
HE2-012M	26400	12000	41.13	1045	15	4.6	16	4.9	15	1	18	5.5	1.5	4	7209	3277	1415	643
HE2-025H	55000	25000	56.50	1435	7.5	2.3	8	2.4	15	2	–	–	–	–	–	–	1235	561
HE2-025M	55000	25000	47.44	1205	7.5	2.3	8	2.4	15	2	18	5.5	1.5	8	14135	6425	1835	834
HE2-037H	81400	37000	71.88	1826	5	1.5	5.5	1.7	15	3	–	–	–	–	–	–	2230	1014
HE2-037M	81400	37000	54.19	1376	5	1.5	5.5	1.7	15	3	18	5.5	1.5	8	10751	4887	3700	1682
HE2-050H	110000	50000	80.44	2043	3.7	1.1	4.3	1.3	15	4	–	–	–	–	–	–	2995	1361
HE2-050M	110000	50000	58.25	1480	3.7	1.1	4.3	1.3	15	4	18	5.5	1.5	8	14304	6502	4665	2120

Hercu-Link™ Electric Chain Hoist

5 to 50 metric ton capacity



Dimensions: hook mounted hoist

Frame 1	A		B		B ¹		C		F		G		H	
	in.	mm	in.	mm	in.	mm	in.	mm	in.	mm	in.	mm	in.	mm
HE1-005H	34.44	875	13.00	330	21.75	552	25.44	646	1.81	46	22.75	578	21.50	546
HE1-010H	41.81	1062	13.00	330	21.75	552	25.44	646	2.63	67	22.75	578	21.50	546
HE1-015H	48.13	1222	13.00	330	27.94	710	31.44	799	3.00	76	22.75	578	21.50	546
HE1-020H	49.50	1257	13.63	346	22.25	565	25.44	646	3.63	92	25 1/4	641	23.50	597
	J		K		L		M		N		P		Y	
HE1-005H	37.00	940	9.50	241	10.50	267	3.50	89	3.50	89	1.88	48	6.50	165
HE1-010H	45.81	1167	9.50	241	10.50	267	6.00	152	8.50	216	2.50	64	8.69	221
HE1-015H	53.63	1362	9.50	241	10.50	267	5.25	133	10.00	254	3.38	86	11.00	279
HE1-020H	55.50	1409	9.50	241	10.50	267	9.38	238	8.50	216	4.00	102	13.63	346
Frame 2	A		B		B ¹		C		F		G		H	
	in.	mm	in.	mm	in.	mm	in.	mm	in.	mm	in.	mm	in.	mm
HE2-012H	43.00	1092	19.63	498	28.75	730	33.00	838	2.63	67	28.13	714	21.00	533
HE2-025H	58.63	1489	19.63	498	28.75	730	33.00	838	3.63	92	28.13	714	21.00	533
HE2-037H	71.88	1826	20.75	527	28.75	730	33.00	838	5.06	129	31.13	791	24.00	610
HE2-050H	80.44	2043	20.75	527	28.75	730	33.00	838	6.69	170	31.13	791	24.00	610
	J		K		L		M		N		P		Y	
HE2-012H	48.13	1222	9.69	246	10.88	276	4.50	114	4.50	114	2.25	57	8.69	221
HE2-025H	66.00	1676	9.69	246	10.88	276	6.88	175	11.13	286	3.25	83	13.63	346
HE2-037H	82.00	2083	9.69	246	10.88	276	11.13	283	11.13	286	4.25	108	15.44	392
HE2-050H	93.81	2383	9.69	246	10.88	276	12.63	321	11.13	286	6.50	165	20.63	524

Frame 1 uses 16 mm chain; frame 2 uses 22 mm chain.

Chain bucket includes trailing trolley on HE1-015M and any other 4 wheel trolley model with 35 feet (10.7 m) of lift or more.

Hook mounted hoist

Frame 1: HE1-005H, HE1-010H,
HE1-015H, HE1-020H

Frame 2: HE2-012H, HE2-025H,
HE2-037H, HE2-050H

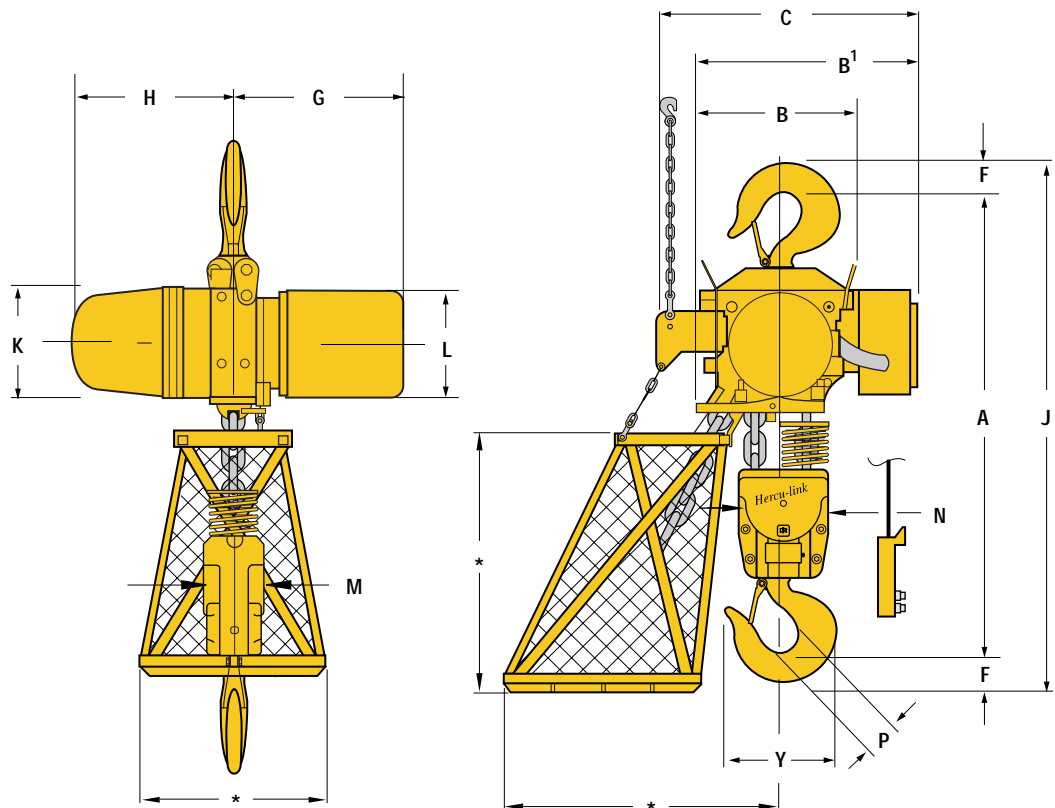

Dimensions are subject to change. Contact factory for certified prints

Hercu-Link™ Electric Chain Hoist

5 to 50 metric ton capacity



Dimensions: trolley mounted hoist; frame 1 with 16 mm chain

Frame 1	A		B		C		D		E		F		G		H	
	in.	mm	in.	mm	in.	mm	in.	mm	in.	mm	in.	mm	in.	mm	in.	mm
HE1-005M	30.50	775	27.31	694	3.88	98	—	—	7.75	197	1.81	46	22.75	578	21.50	546
HE1-010M	36.94	938	27.31	694	3.88	98	—	—	7.75	197	2.59	66	22.75	578	21.50	546
HE1-015M	41.63	1051	30.56	776	4.50	114	—	—	9.00	229	3.00	76	22.75	578	21.50	546
HE1-020M	41.44	1053	32.00	813	5.88	149	—	—	11.75	298	3.63	92	25.25	641	23.50	597
	J		K		L		M		N		O		P		Q	
HE1-005M	41.44	1064	9.50	241	10.50	267	3.50	89	3.50	89	10.06	256	1.88	48	6.13	156
HE1-010M	49.63	1260	9.50	241	10.50	267	6.00	152	8.50	216	10.06	256	2.50	64	6.13	156
HE1-015M	56.63	1387	9.50	241	10.50	267	5.25	133	10.00	254	10.75	273	3.38	86	6.88	175
HE1-020M	56.06	1424	9.50	241	10.50	267	9.44	240	8.50	216	12.19	310	4.00	102	9.00	229
	R		S		T		W		X		Y		Z			
HE1-005M	7.25	184	2.63	67	1.94	49	19.81	503	5.00	127	6.50	165	—	—		
HE1-010M	7.25	184	2.63	67	1.94	49	19.81	503	5.00	127	8.69	221	—	—		
HE1-015M	8.63	219	3.25	83	2.56	65	20.00	508	8.88	225	11.00	279	—	—		
HE1-020M	11.38	289	3.06	78	2 3/16	56	19.50	495	6.00	152	13.63	346	—	—		

Important:
It is the user's responsibility to specify proper beam size for the maximum wheel loading. Consult w/a qualified engineer.

Chain bucket includes trailing trolley on HE1-015M and any other 4 wheel trolley model with 35 feet (10.7 m) of lift or more.

4-wheel motorized trolley
Frame 1: HE1-005M, HE1-010M, HE1-015M, HE1-020M
Frame 2: HE2-012M
 (see Frame 2 dimensions on following page)

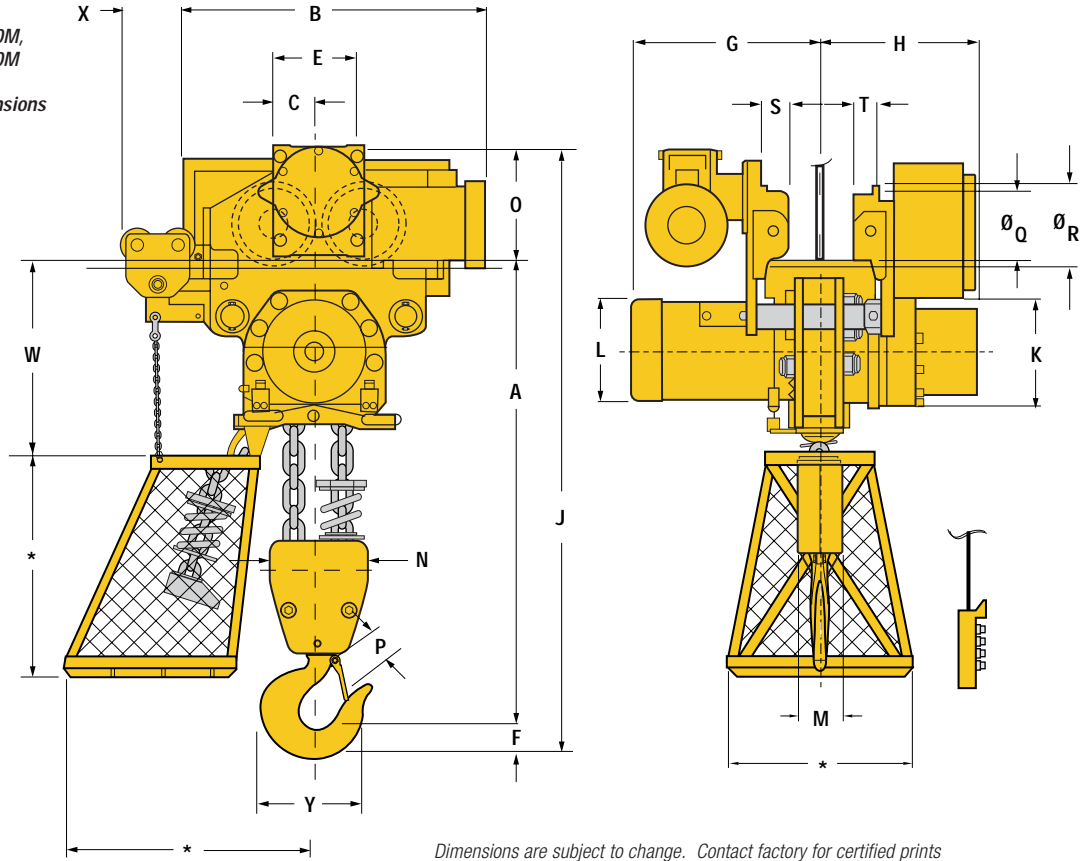

Dimensions are subject to change. Contact factory for certified prints

Hercu-Link™ Electric Chain Hoist

5 to 50 metric ton capacity



Dimensions: trolley mounted hoist with 22 mm chain

Frame 2	A		B		C		D		E		F		G		H	
	in.	mm	in.	mm	in.	mm	in.	mm	in.	mm	in.	mm	in.	mm	in.	mm
HE2-012M	41.13	1045	32.81	833	4.50	114	–	–	9.00	229	2.56	65	28.13	714	21.00	533
HE2-025M	47.44	1205	62.13	1578	19.00	483	24.50	622	9.00	229	3.63	92	28.13	714	21.00	533
HE2-037M	54.19	1376	64.88	1648	24.00	610	26.50	673	11.75	298	5.06	129	31.13	791	24.00	610
HE2-050M	58.25	1480	64.88	1648	24.00	610	26.50	673	11.75	298	6.69	170	31.13	791	24.00	610
	J		K		L		M		N		O		P		Q	
HE2-012M	54.50	1384	9.69	246	10.88	276	4.50	114	4.50	114	10.75	273	2.25	57	6.88	175
HE2-025M	62.81	1595	9.69	246	10.88	276	6.88	175	11.25	286	11.56	294	4.00	102	6.88	175
HE2-037M	72.25	1835	9.69	246	10.88	276	11 1/8	283	11.25	286	13.00	330	4.75	121	9.00	229
HE2-050M	77.94	1980	9.69	246	10.88	276	12.63	321	11.25	286	13.00	330	6.50	165	9.00	229
	R		S		T		W		X		Y		Z			
HE2-012M	8.63	219	3.25	83	2.56	65	24.44	621	8.88	225	8.69	221	–	–		
HE2-025M	8.63	219	3.19	81	2.56	65	18.50	470	–	–	13.63	346	21.50	546		
HE2-037M	11.38	289	3.19	81	2.25	57	19.19	487	–	–	15.44	392	24.50	622		
HE2-050M	11.38	289	3.19	81	2.25	57	19.19	487	–	–	20.63	524	24.50	622		

Important:
It is the user's responsibility to specify proper beam size for the maximum wheel loading. Consult w/a qualified engineer.

8-wheel motorized trolley
Frame 2:
(HE2-025M,
HE2-037M,
HE2-050M)

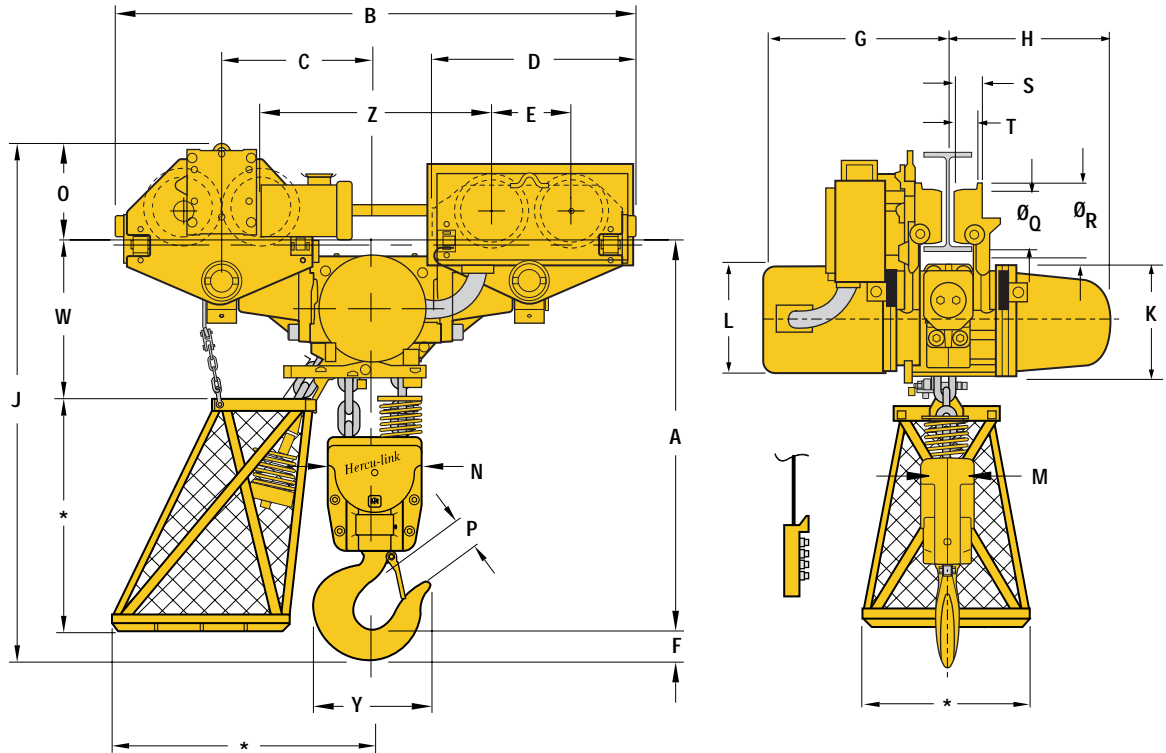

Dimensions are subject to change. Contact factory for certified prints

Hercu-Link™ Electric Chain Hoist

5 to 50 metric ton capacity



How to Order:

Specify the complete model as shown. Specify beam size, type and flange width. **Example: HE1-005MA3-30-27-4P**

Series	Frame size	- Capacity	Suspension	Trolley flange adj.	Control	- Lift	- Control drop	Voltage	Options																													
HE	1	- 005	M	A	3	- 30	- 27	4	P																													
<p>H = Hercu-Link series</p> <p>A = Electrically powered</p> <p>Note: See Air Hercu-Link section for air and hydraulic models.</p>			<p>H = Top hook mount</p> <p>C = Clevis mount⁽¹⁾</p> <p>D = Deck mount⁽¹⁾</p> <p>P = Plain trolley</p> <p>G = Geared trolley</p> <p>M = Electric motor trolley</p>			<p>XX = Length of lift</p> <p>XX = Control drop pendent (6 ft/2m standard)</p>			<p>1 = 208-3-60</p> <p>2 = 230-3-60</p> <p>3 = 380-3-50</p> <p>4 = 460-3-60</p> <p>5 = 575-3-60</p> <p>6 = 415-3-50</p> <p>7 = 400-3-50</p>																													
<table border="0"> <tr> <td></td> <td>tons</td> <td>lbs.</td> </tr> <tr> <td>1</td> <td>005</td> <td>= 5 = 11,000</td> </tr> <tr> <td></td> <td>010</td> <td>= 10 = 22,000</td> </tr> <tr> <td></td> <td>015</td> <td>= 15 = 33,000</td> </tr> <tr> <td></td> <td>020</td> <td>= 20 = 44,000</td> </tr> <tr> <td>2</td> <td>012</td> <td>= 12.5 = 27,500</td> </tr> <tr> <td></td> <td>025</td> <td>= 25 = 55,000</td> </tr> <tr> <td></td> <td>037</td> <td>= 37.5 = 82,500</td> </tr> <tr> <td></td> <td>050</td> <td>= 50 = 110,000</td> </tr> </table>				tons	lbs.	1	005	= 5 = 11,000		010	= 10 = 22,000		015	= 15 = 33,000		020	= 20 = 44,000	2	012	= 12.5 = 27,500		025	= 25 = 55,000		037	= 37.5 = 82,500		050	= 50 = 110,000	<p>A = Standard</p> <p>B = 2" (50.8 mm) extension</p> <p>C = 4" (101.6 mm) extension</p> <p>D = 6" (152.4 mm) extension</p> <p>M = No trolley; used with hook, clevis and deck mount</p>			<p>2 = 1 motor pendent (2 button)</p> <p>3 = 2 motor pendent (4 button)</p> <p>4 = 3 motor pendent (6 button)</p> <p>5 = 1 motor pendent with mainline disconnect</p> <p>6 = 2 motor pendent with mainline disconnect</p> <p>7 = 3 motor pendent with mainline disconnect</p>			<p>Hoist</p> <p>D = Dual speed</p> <p>L = Electronic overload protection</p> <p>P = Marine 812 finish</p> <p>Q = Special paint; specify</p> <p>T = Galvanized chain container</p> <p>Y = Hull bumpers</p> <p>Z = Sandblast & carbozinc primer</p>		
	tons	lbs.																																				
1	005	= 5 = 11,000																																				
	010	= 10 = 22,000																																				
	015	= 15 = 33,000																																				
	020	= 20 = 44,000																																				
2	012	= 12.5 = 27,500																																				
	025	= 25 = 55,000																																				
	037	= 37.5 = 82,500																																				
	050	= 50 = 110,000																																				
						<p>Trolley</p> <p>B = Trolley bumpers⁽²⁾</p> <p>G = Trolley guide rollers⁽²⁾</p> <p>K = Clevis in lieu of bottom hook⁽¹⁾</p> <p>R = Copper plated S•COR•E pkg (see description below)</p> <p>S = Solid bronze S•COR•E pkg (see description below)</p>																																

(1) P.O.A. Contact Technical Sales.
 (2) Standard on Frame 2 models

■ **S•COR•E (Option codes R and S)**

- R** = The product will be equipped with zinc plated load chain, copper plated load hook(s) and trolley wheels. Zinc plated hand chain if applicable.
- S** = Up to 20 ton units will be equipped with zinc plated load chain, solid bronze load hook(s) and trolley wheels. Zinc plated hand chain if applicable.