

The current design of Force 5 Man Rider air winches has been extended to meet the requirements of the American National Standard, ANSI/ASME A10.22-1990 for “Rope-Guided and Nonguided Worker’s Hoists - Safety Requirements.”

Man Rider winches, when incorporated into a lifting system as prescribed in the Standard, or by local regulations, are suitable for lifting and lowering people. They are also rated for lifting material without people.

Since this design is to a recognized ANSI / ASME standard, these Man Rider air winches address OSHA requirements where applicable. IR engineering and manufacturing expertise plus third party Type Approval by the American Bureau of Shipping is your assurance of quality, dependability, and conformity.

■ Standard features

- All ANSI / ASME Standard Man Riders carry the designation “MRA - Man Rider, ANSI / ASME” in the model code
- Battery powered line speed monitor and payout meter with 120 volt charger
- Display and battery charger enclosures conform to NEMA 13 and JIC standard EGP-1-1967
- Electrical grounding lug
- Dual drum brakes: one automatic and one manual
- Automatic spring return “lift & shift” double action throttle lever prevents accidental starts
- Dual rated at 8:1 design factor for personnel lifting and 5:1 design factor for utility lifting
- Up and down limit switches are easily adjusted and locked to prevent overtravel



FA2MRA24MA1

- Exhaust manifold, ten feet of exhaust hose and muffler are included to keep sound levels below 90 dBA
- Owner’s manual and ANSI / ASME Standard included in weatherproof box attached to winch
- Test certificate verifying performance and required brake holding capacity

■ Options

- Different drum lengths
- Remote pilot pendent with overspeed warning light
- Disc brake
- Grooved drum
- Drum guard
- Corrosion resistant marine grade coating system: sandblast to white metal finish and carbozinc primer with a Marine 812 finish
- “Electric-Over-Air” controls for extended remote control operation

Specifications: performance is based on 90 psi (6.3 bar) air inlet pressure with motor running

Model no.	Lifting capacity				Stall pull		Required rope size ⁽¹⁾		Drum rope storage capacity				Shipping weight	
	Personnel		Utility		lbs	kg	in.	mm	Personnel		Utility		lbs	kg
	lbs	kg	lbs	kg	lbs	kg			ft	m	ft	m	lbs	kg
FA2MRA24MA1	2200	1000	3520	1600	9000	4090	7/16	12	808	246	1000	305	1087	493
FA2.5MRA24MA1	2200	1000	3520	1600	10000	4545	7/16	12	808	246	1000	305	1275	578
FA5MRA24MA1	4400	2000	7040	3200	24000	10909	5/8	16	1024	312	1456	444	2260	1025

(1) Rope construction: Only 6 x 19, 6 x 37 classification, or rotation-resistance ropes, all with IWRC, shall be used.

Drum speed at third layer (half drum)

Model no.	At 330 lbs / 136 kg				At personnel rating				At utility rating			
	Up		Down		Up		Down		Up		Down	
	fpm	m/min	fpm	m/min	fpm	m/min	fpm	m/min	fpm	m/min	fpm	m/min
FA2MRA24MA1	95	29.3	52	15.8	91	28	71	22	66	20	120	37
FA2.5MRA24MA1	150	45.7	115	35.1	195	59	136	41	157	48	148	45
FA5MRA24MA1	77	23.5	52	15.8	87	26	69	21	74	22	78	24

All performance specifications are based on rope diameter of 7/16" (11 mm) for FA2MRA and FA2.5MRA and 5/8" (16 mm) diameter for FA5MRA as required to meet ANSI / ASME A10.22 - 1990.

Force 5™ "Onshore" Man Rider™ Series 2200 and 4400 lb (1000 and 2000 kg) capacity



Dimensions: ANSI / ASME Man Rider FA5MRA

Drum length		A		B		C		D		E		F	
in.	mm	in.	mm	in.	mm	in.	mm	in.	mm	in.	mm	in.	mm
8.0	203	26.63	676	1.31	33	8.00	203	50.00	1270	12.00	305		
12.0	305	30.63	778	1.44	37	9.25	235	54.00	1372	13.88	353		
16.0	406	34.63	880	1.56	40	10.50	267	58.00	1473	15.75	400		
24.0	610	42.63	1083	1.81	46	13.50	330	66.00	1676	19.50	495		
30.0	762	48.63	1235	1.31	33	11.50	292	72.00	1829	23.00	584		
36.0	914	54.63	1388	2.31	59	12.50	318	78.00	1981	25.00	635		

Wire rope storage capacity^{(1), (2)}

Series	Drum length		5/8" 16mm	
	in.	mm	ft	m
FA5MRA	8	203	341	104
	12	305	512	156
	16	406	683	208
	24	610	1024	312
	30	762	1280	390
	36	914	1536	468

- (1) Recommended working capacity is 80% of values shown.
 (2) ANSI / ASME A10.22-1990 requires top layer be 2 in. (50.8 mm) or more below drum flange

FA5MRA in inches (mm)

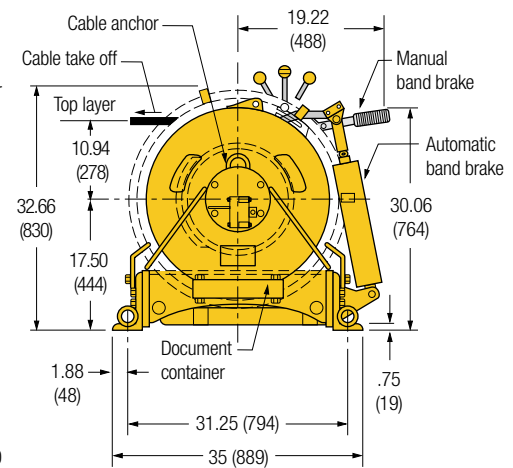
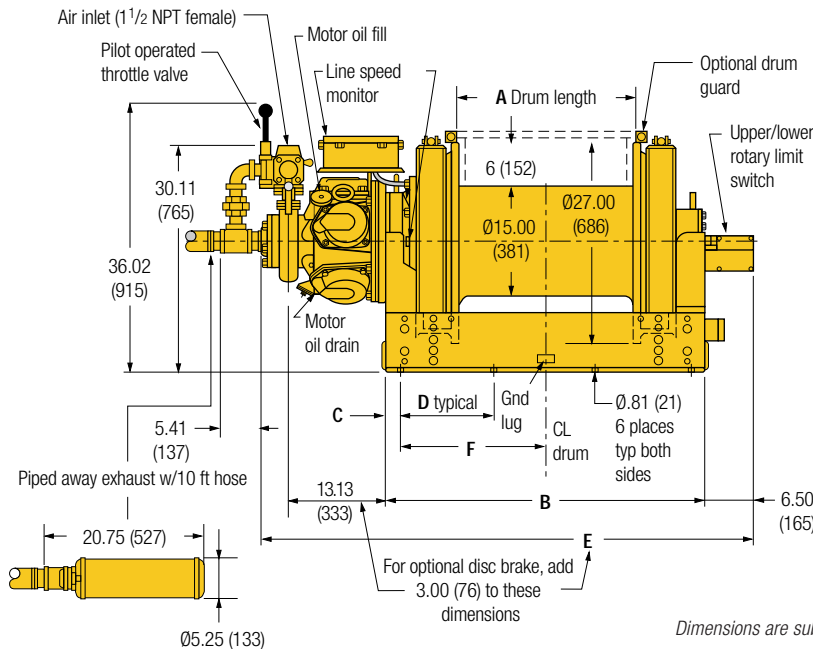

Dimensions are subject to change. Contact factory for certified prints

How to Order:

Specify winch by complete model number. Man Rider winches will not be sold without standard features. Add options as required. **Example: FA2MRA24MA1G**

Series	Man Rider Capacity	Designation	Drum length	Brakes	Controls	Options
FA	2	MRA	24	MA	1	G
FA	2 = 2200 lbs / 1000 kg 2.5 = 2200 lbs / 1000 kg 5 = 4400 lbs / 2000 kg	MRA = Meets ANSI / ASME A10.22-1990 standard	8 = 8 in. (203mm) 12 = 12 in. (305 mm) 16 = 16 in. (406 mm) 24 = 24 in. (610 mm) (standard) 30 = 30 in. (762 mm) 36 = 36 in. (914 mm)	M = Manual drum (standard) A = Auto drum (standard) K = Auto disc (optional)	1 = Standard winch mounted lever throttle 3XX = Remote pilot pendent throttle w/warning light; 6 ft/2m std. Max 50 ft (15 m). 5XX = Remote electric-over air throttle control XX = Specify hose length in feet	
Force Five	FA = Air powered					7 = Drum grooving (no. = wire rope size in sixteenths, e.g. 7/16 in.; 7 for FA2 and FA2.5 only; 10 for FA5 only) G = Drum guard P = Marine 812 finish V = Press roller Z = Sandblast and carbozinc primer