

# Third Generation "Offshore" Gulf Man Rider™ 2500 lb (1136 kg) capacity



Based on the design of our Force 5 Man Riders and the popular FA2B modular winch, IR is pleased to introduce the FA2B-GMR, the Gulf Man Rider™

When operating in the Gulf of Mexico, the guidelines of certifying bodies may not apply, but common sense and safe operating practices do. The **Gulf Man Rider™** is IR's solution. It meets all the offshore and rating criteria we apply to all Man Riders. We also provide a third party (DNV) witness certificate with performance specifications; this is your assurance of quality and reliability.

### Standard features:

- Dual brakes: auto disc and manual band type. Both are capable of holding 200% of the rated load.
- 8:1 design factor: The recommended wire rope size to maintain this factor is 1/2 in. (13 mm) extra improved plow steel (EIPS) with independent wire rope core (IWRC).
- Stainless steel and corrosion resistant fasteners
- Standard design temperature of 0° C
- Self closing, dual action throttle handle is offshore tough
- Wedge type rope anchor for easy, "tool-less" installation holds up to 80% of rope breaking strength



FA2B-GMR-LMK1G

- Available in short **S**, medium **M**, long **L** and extra long **R** drum lengths
- Dual rated 8:1 design factor for manrider rating; 5:1 design factor for utility rating

### Options:

- Unlike our other Man Riders, drum guards are optional on Gulf Man Riders. Add suffix **G** for this highly recommended option.
- There is no **-E** European version

### Specifications and performance at 90 psi

Model no.	Ratings at mid layer		Optional design temp	Maximum stall pull		Average air consumption		Pipe inlet	Hose size	Shipping weight	
	Utility lbs	Personnel kg		lbs	kg	scfm	m³/min			in.	mm
FA2B-GMR	4000	1818	2500 1136	-10° or -20°c	6800 3084	380 10.8	1 1/4 32	1 1/2 38	786 357		

### Rope speed at mid drum at 90 psi

Winch series	at 330 lbs (150 kg)				at personnel rating				at utility rating			
	Up		Down		Up		Down		Up		Down	
	fpm	m/min	fpm	m/min	fpm	m/min	fpm	m/min	fpm	m/min	fpm	m/min
FA2B-GMR	274	90	150	46	164	54	141	43	96	31	260	79

### Dimensions: FA2B-GMR

Model no.	A		B		C		D	
	in.	mm	in.	mm	in.	mm	in.	mm
FA2B-GMR-SMK1	7.0	178	34.3	871	12.3	312	4.8	121
FA2B-GMR-MMK1	13.5	343	40.8	1036	18.8	478	8.0	204
FA2B-GMR-LMK1	20.0	508	47.3	1201	25.3	643	11.3	286
FA2B-GMR-RMK1	24.0	610	51.3	1303	29.3	744	13.3	337

### FA2B-GMR in inches (mm)

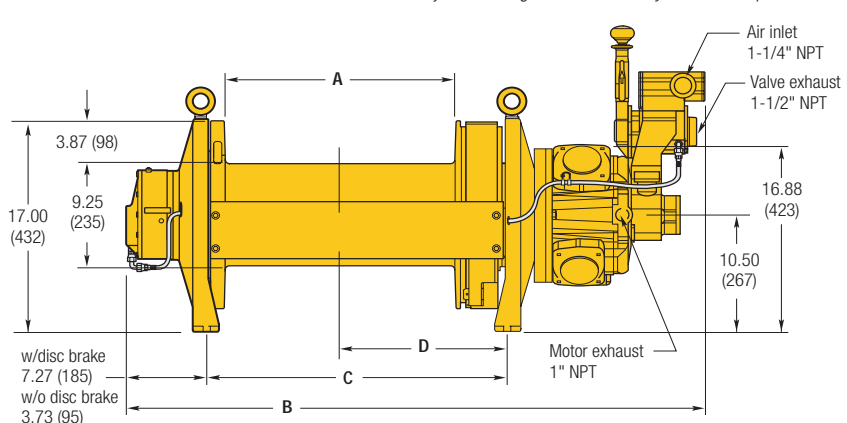
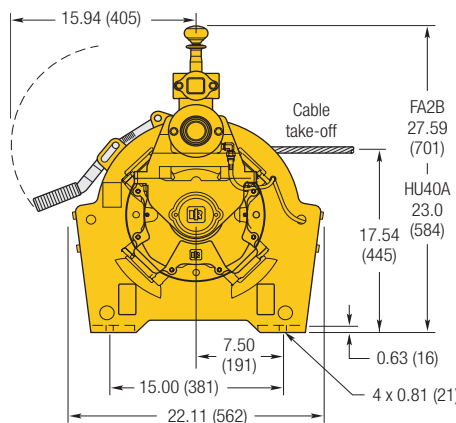

Dimensions are subject to change. Contact factory for certified prints

### Drum storage<sup>(1)</sup>

Model no.	Drum code	Drum length		Rope dia. 1/2 (13)	
		in.	mm	ft	m
FA2B	S	7	178	300	91
	M	13.5	343	600	183
	L	20	508	900	274
	R	24	610	1085	331

(1) Leaving 1/2 inch (13 mm) flange clearance

### How to Order:

Specify FA2B-GMR-"X"MK1 and substitute S, M, L or R for the "X" for drum length. Add suffix G for drum guard option. See Third Generation section for additional information and options.

Example: **FA2B-GMR-LMK1G**