

Force 5™ “Offshore” Man Rider™ Series

330 to 6870 lb (150 to 3117 kg) capacity



Known worldwide as the standard for meeting the toughest personnel lifting requirements in the offshore industry.

Dual rated for personnel and utility lifting applications, these winches have Type Approval or Independent Review certificates issued by the classification societies of ABS, DNV or LRS. Meet NPD, NMD and UK HSE regulations for personnel lifting operations. Oil field tough to weather the harsh environments in marine applications.

Definitions

■ **Third party:** An independent certifying agency that offers formalized review and approval programs for Man Rider winches accepted for suitability to lift personnel. Recognized third party agencies are:

- American Bureau of Shipping (ABS)
- Det Norske Veritas (DNV)
- Lloyd’s Register of Shipping (LRS)

■ **Type Approval:** A comprehensive design review by an independent third party which examines the intended service and application, winch ratings, design calculations of load bearing components, product specifications and service restrictions or limitations. A plant survey is also conducted to verify that quality control procedures and features are adequate and consistent. Upon successful completion, a **Type Approval** certificate is issued.

■ **Third Party Certification:** A review process of quality by an independent third party requested by the customer. Includes:

1. Type Approval certificate (design)
2. Third party survey during manufacturing (quality)
3. Third party witness of performance testing (quality)
4. Issuance of certificates as required by regulatory agency acknowledging compliance.

Standard features:

- Enclosed automatic oil bath “wet” disc brake is fully sealed against salt spray, dirt or moisture and provides trouble-free operation over thousands of lifting cycles.
- Manual drum mounted band brake for additional braking by operator
- Internal gearbox / disc brake combination for superior load control
- Corrosion resistant drum guard supports the weight of a 200 lb/ 91 kg person.



FA150KGMR

- Dual rated 8:1 design factor for manrider rating; 5:1 design factor for utility rating
- Compact, frame and fabricated alloy steel drum fit into tight spaces
- Standard operating temperature range is 0°C through 60°C; optional design temperature of -10°C or -20°C
- Minimum 18:1 drum diameter to wire rope diameter ratio reduces wire rope wear.
- Data book and “Type Approval” certificates available upon request.
- Marine 812 paint system on FA150KGMR models.

Options and accessories:

- Automatic band brakes
- Variable drum lengths
- Grooved drums
- Drum divider flange
- Upper and lower limit switches
- Corrosion resistant marine grade coating system: sandblast to white metal finish and carbozinc primer with a Marine 812 finish
- Remote controls
- Air prep package: filter, lubricator, strainer, liquidator and regulator
- Muffler
- Hydraulic models
- Electric-Over-Air remote control pendant for unlimited pendant length
- Third party certifications for low temperature applications

Specifications: performance is based on 90 psi (6.3 bar) air inlet pressure with motor running

Model no.	Force 5 MR ratings at top layer				Personnel rating		Maximum		Average air		Pipe		Hose		Shipping	
	Personnel (1)		Utility (2)		avg line speed	stall pull	lbs	kg	scfm	m ³ /min	in.	mm	in.	mm	lbs	kg
	lbs	kg	lbs	kg	fpm	m/min										
FA150KG12MR-1-E	330	150	n/a	n/a	87	26	(3)	(3)	50	1.4	0.5	13	3/4	19	750	340
FA2MR24MK1G	3180	1445	4400	2000	75	23	9000	4090	335	9.5	1 1/4	32	1 1/4	32	906	411
FA2.5MR24MK1G	3180	1445	5000	2273	159	48	10000	4545	700	19.9	1 1/4	32	1 1/2	38	1178	534
FA5MR24MK1G	6870	3123	11000	5000	69	21	24000	10909	700	19.9	1 1/4	32	1 1/2	38	2020	916
Force 5 Third Generation Man Rider Series ratings at mid layer (4)																
FA2BMR-MK1G	2500	1136	4000	1818	168	51	6800	3084	380	10.8	1 1/4	32	1 1/2	38	786	357
FA2.5AMR-MK1G	3125	1420	5000	2273	173	53	10400	4727	560	15.9	1 1/4	32	1 1/2	38	905	411
FA5AMR-MK1G	6250	2841	10000	4545	102	31	17000	7727	600	17.0	1 1/4	32	1 1/2	38	1842	837

(1) “-E” models for European Union allow one lift capacity rating only; i.e., only personnel lift rating is allowed for both personnel and utility applications.

(2) Utility rating only for those countries that allow dual ratings, e.g. USA.

(3) Per NPD regulations

(4) Third Generation Man Riders are not available in CE format.

Rope storage for personnel lifting⁽¹⁾

Model number	Drum length		10mm		Rope diameter			
	in.	mm	ft	m	1/2"	13mm	3/4"	19mm
FA150KGMR	8	203	474	144	—	—	—	—
	12	305	723	220	—	—	—	—
	16	406	972	296	—	—	—	—
	24	610	1470	448	—	—	—	—
FA2MR and FA2.5MR	8	203	—	—	321	97	—	—
	12	305	—	—	492	150	—	—
	16	406	—	—	663	202	—	—
	24	610	—	—	1006	306	—	—

Model number	Drum length		10mm		Rope diameter			
	in.	mm	ft	m	1/2"	13mm	3/4"	19mm
FA5MR	8	203	—	—	—	—	235	72
	12	305	—	—	—	—	365	111
	16	406	—	—	—	—	495	151
	24	610	—	—	—	—	755	230
FA2BMR and FA2.5AMR	S 7	178	—	—	198	60	—	—
	M 13.5	343	—	—	396	120	—	—
	L 20	508	—	—	595	181	—	—
FA5AMR	R 24	610	—	—	717	218	—	—
	S 12	305	—	—	—	—	321	98
	L 24	610	—	—	—	—	663	202

(1) Based on UK HSE standards requiring top layer to be 2 1/2 times the wire rope diameter below drum flange.

Rope speed at mid drum at 90 psi

Winch series	at 330 lbs (150 kg)				at personnel rating				at utility rating			
	Up		Down		Up		Down		Up		Down	
	fpm	m/min	fpm	m/min	fpm	m/min	fpm	m/min	fpm	m/min	fpm	m/min
FA150KGMR	87	26	100	31	87	26	100	31	n/a	n/a	n/a	n/a
FA2MR	121	37	60	18	72	22	125	38	53	16	140	43
FA2.5MR	235	71	125	38	160	49	155	47	113	34	190	58
FA5MR	94	29	60	18	69	21	55	17	54	16	70	21
FA2BMR	253	77	—	—	160	49	—	—	102	31	—	—
FA2.5AMR	257	78	—	—	173	53	—	—	117	36	—	—
FA5AMR	177	54	—	—	102	31	—	—	50	15	—	—

Dimensions

FA150KGMR with disc and manual brake in inches (mm)

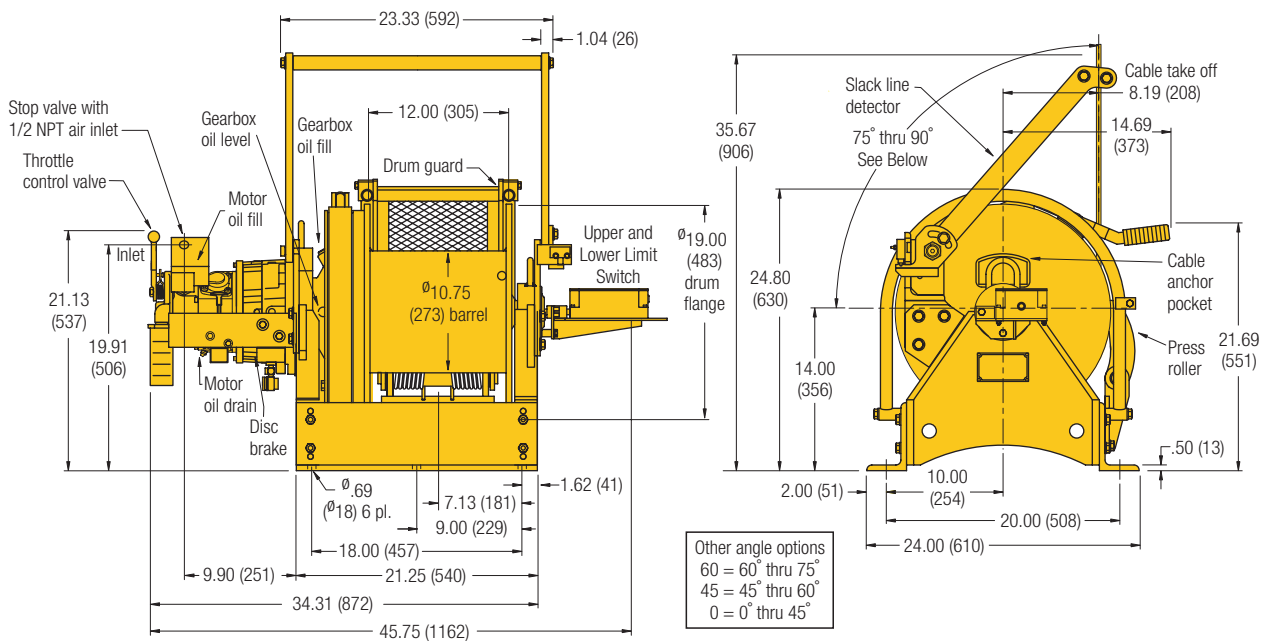

Dimensions are subject to change. Contact factory for certified prints

Force 5™ "Offshore" Man Rider™ Series

330 to 6870 lb (150 to 3117 kg) capacity



Dimensions

FA2MR24MK1G with disc and manual brake in inches (mm)

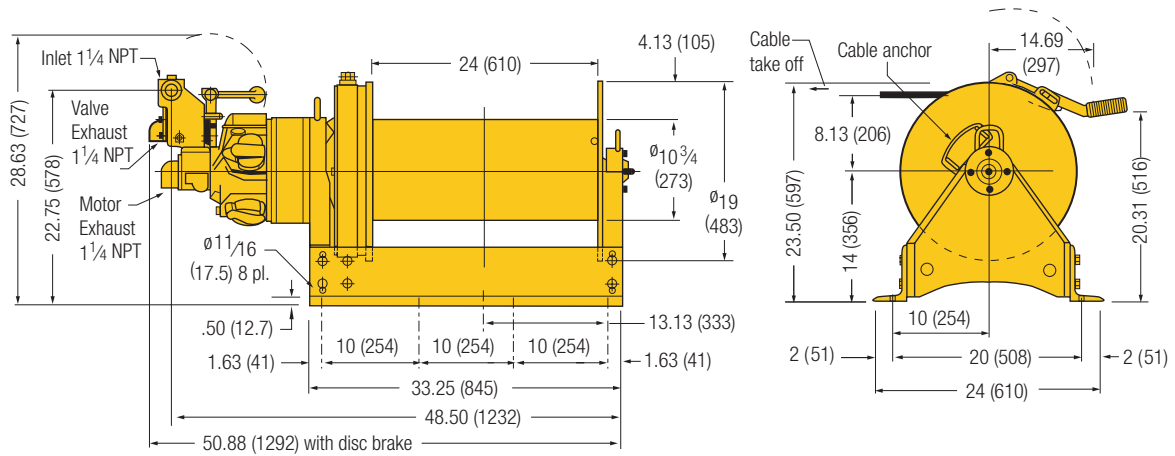

FA2.5MR24MK1G with disc and manual brake in inches (mm)

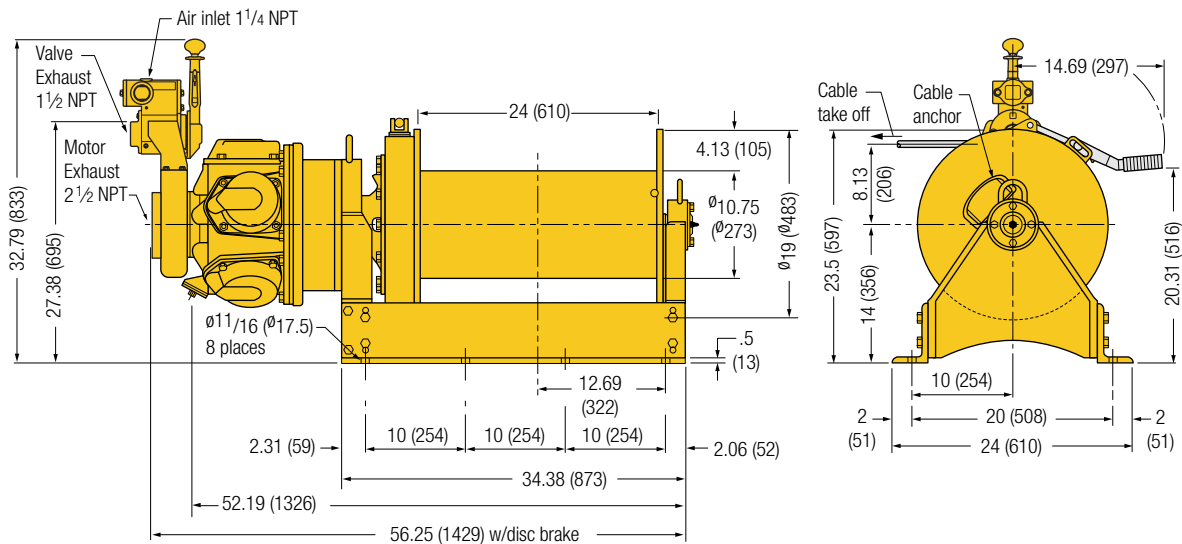

FA5MR24MK1G with disc and manual brake in inches (mm)

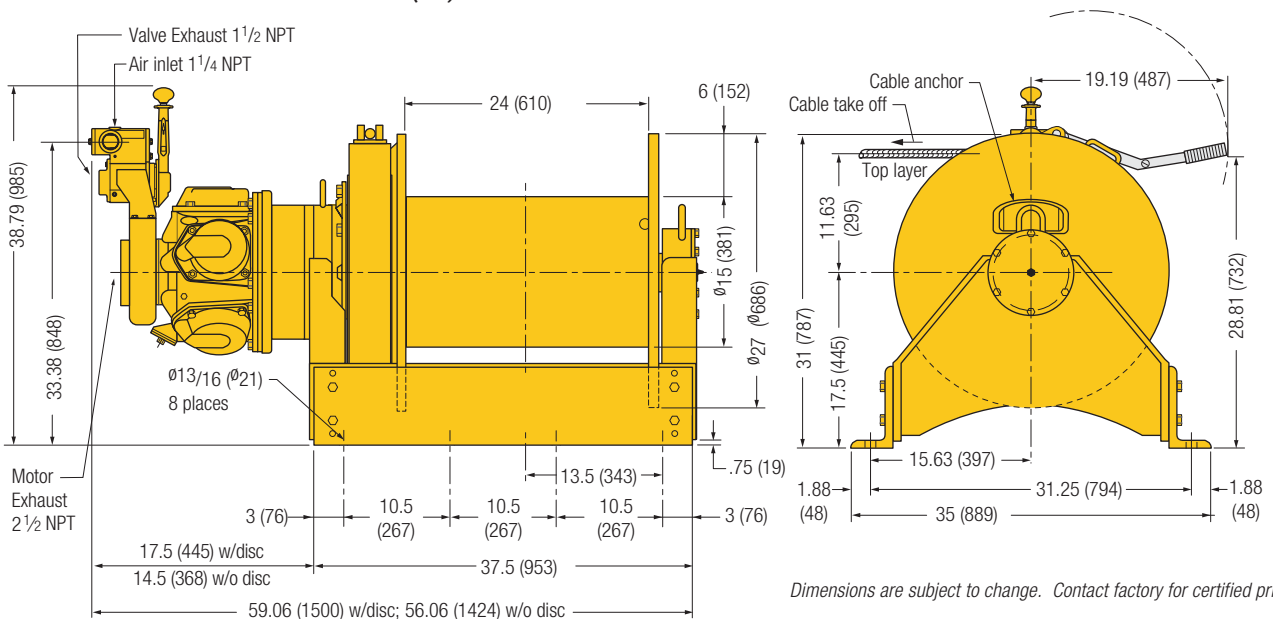

Dimensions are subject to change. Contact factory for certified prints

Force 5™ "Offshore" Man Rider™ Series

330 to 6870 lb (150 to 3117 kg) capacity



Dimensions

Model no.	A		B		C		D	
	in.	mm	in.	mm	in.	mm	in.	mm
FA2BMR-SMK1G	7.0	178	37.4	950	12.3	312	7.5	191
FA2BMR-MMK1G	13.5	343	43.9	1115	18.8	478	10.81	274
FA2BMR-LMK1G	20.0	508	50.4	1280	25.3	643	14.0	356
FA2BMR-RMK1G	24.0	610	54.4	1382	29.3	744	16.0	406

Dimensions

Model no.	A		B		C		D	
	in.	mm	in.	mm	in.	mm	in.	mm
FA2.5AMR-SMK1G	7.0	178	41.19	1046	12.31	313	7.50	191
FA2.5AMR-MMK1G	13.5	343	47.69	1211	18.81	478	10.81	274
FA2.5AMR-LMK1G	20.0	508	54.19	1376	25.31	643	14.00	356
FA2.5AMR-RMK1G	24.0	610	58.19	1478	29.31	744	16.00	406
FA5AMR-SMK1G	12.0	305	46.50	1181	17.89	454	10.50	266
FA5AMR-LMK1G	24.0	610	58.13	1486	29.89	759	16.50	419

FA2BMR in inches (mm)

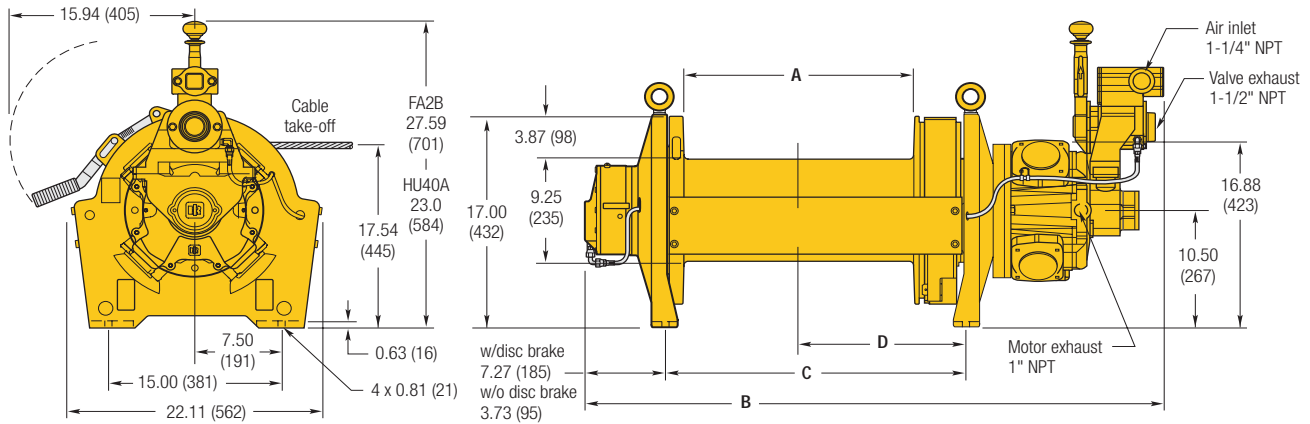

FA2.5AMR in inches (mm)

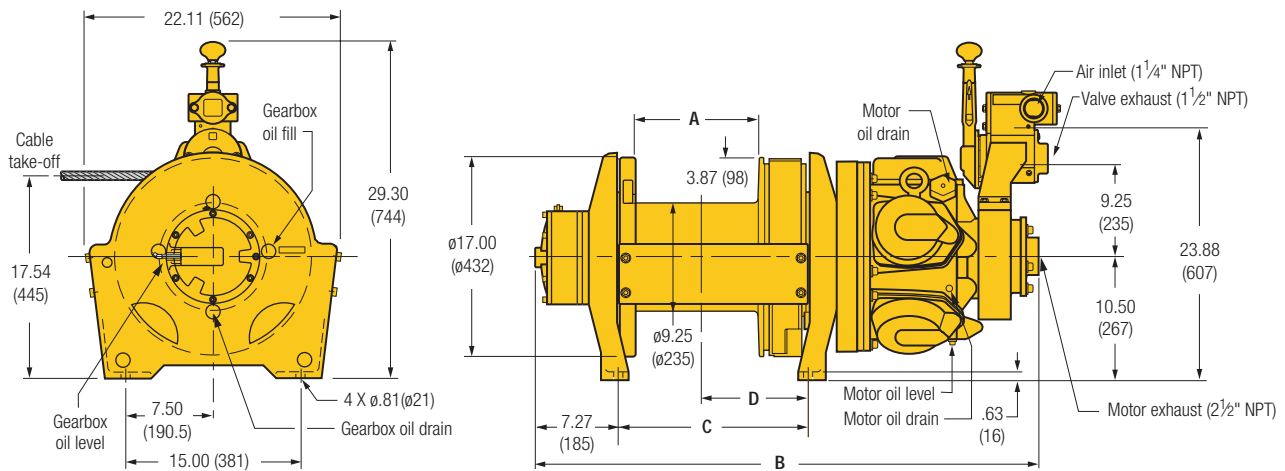

FA5AMR in inches (mm)

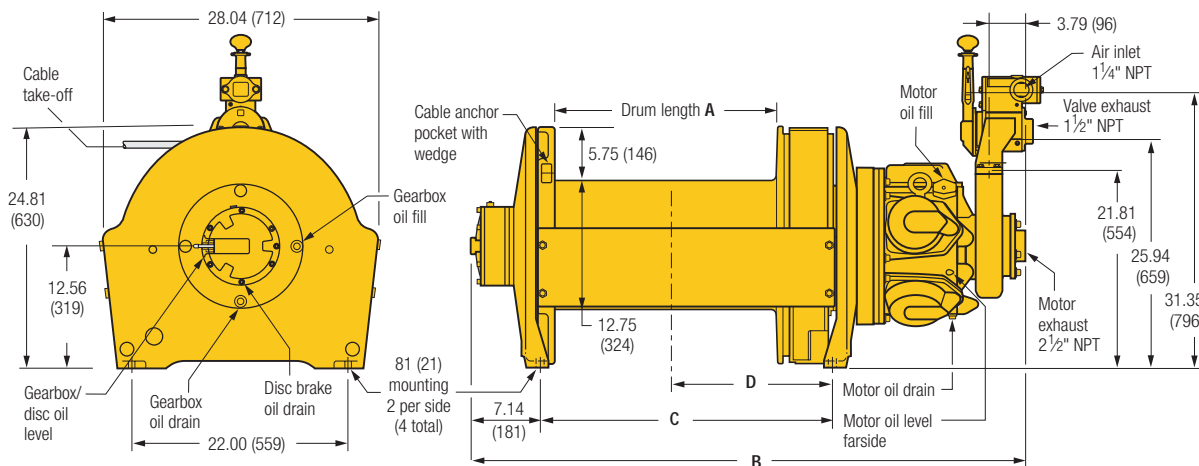

Dimensions are subject to change. Contact factory for certified prints

Force 5™ “Offshore” Man Rider™ Series

330 to 6870 lb (150 to 3117 kg) capacity



How To Order:

Specify complete model code as shown. To order options, use the option code in the option table and add as a suffix to the model code. To order a Force Five air winch with a non-standard drum length, refer to the available drum lengths provided in the drum length table below. Enter the desired drum length for each winch in the drum length section of the model code. To order accessories such as filters and lubricators, enter these as separate accessory items by the part number in the air winch accessories table. **Example: FA2.5MR24MK1GP**

Series	Personnel cap.	Man Rider cap.	Drum length	Drum brake	Disc brake	Control brake	Options (see notes below)
FA	2.5	MR	24	M	K	1	GP
150KG = 330 lbs (150 kg) (Contact technical sales for special model driver)		MR = Man Rider	24 = 24" (610 mm) between flanges. See drum length charts below.	M = Auto drum brake M = Manual drum brake (std)	K = Auto disc (std)	1 = Standard winch mounted throttle	7 = Drum grooving (specify rope size in sixteenths, e.g. 7 = 7/16") ⁽²⁾ C = Low temperature; please specify in text: -10° C or -20° C D = Drum divider flange and additional cable anchor ⁽³⁾ G = Drum guard L = Drum locking pin ⁽⁵⁾ M1 = Per DIN 50049/En10204 Para 2.2 "Typicals" ⁽⁴⁾ M2 = Per DIN 50049/En10204 Para 3.1b actual per product as purchased ⁽⁴⁾ M3 = Per DIN 50049/En10204 Para 3.1b actual per product as delivered in final condition ⁽⁴⁾ N = Type approval; please specify in text: DNV, ABS or Lloyds P = Corrosion resistant marine grade coating system: sandblast to white metal finish and carbozinc primer with a Marine 812 finish Q = Special paint; please specify S = Limit switch (upper and lower) ⁽⁵⁾ U = Underwound (available only with autodisc brake XX) V = Press roller W = Witness; please specify X = Special testing; please specify Z = Sandblast and carbozinc primer only -E = Compliance with European Machinery Directive (insert at end of model code) ⁽⁵⁾
2B = 2500 lbs (1136 kg)	2.5A = 3125 lbs (1420 kg)	2 = 3180 lbs (1445 kg)	2XX = Remote full flow lever throttle (max 20 ft/6 m)	A = Auto drum brake		3XX = Remote pilot pendent throttle (std = 6 ft/1.8 m; max 66 ft/20 m) ⁽¹⁾	
2.5 = 3180 lbs (1445 kg)	5A = 6250 lbs (2841 kg)	5 = 6870 lbs (3111 kg)	4XX = Remote pilot lever throttle (std = 6 ft/1.8 m; max 66 ft/20 m) ⁽¹⁾			5XX = Remote electric over air throttle	
Force Five			XX = Specify hose length or pendent cord in feet				
FA = Air powered							
FH = Hydraulic powered							
Notes:							
All Force 5 units come with standard six (6) strand wire rope anchor and winding directions for right hand overwind.							
Option Notes:							
(1) With remote pilot control option, line speeds will decrease.							
(2) Number designates drum grooving. Number equals wire rope size in sixteenths. The standard will be based on a right hand overwind rotation and spiral grooving for the recommended size of wire rope for the standard length of drum only. Grooving involving longer or shorter drums, or drums equipped with a divider flange will be an engineered item with longer lead time.							
(3) D = drum divider flange. The standard will be based on right hand over wind rotation. Two steel flanges are welded to the center of the drum. This provides the motor side of the drum (half) with a rope anchor. Anchor locations must be specified by the customer.							
(4) Documentation, witness testing and material traceability available; must be requested at time of order. Specify options or contact factory or your nearest IR distributor for information.							
M1 Material traceability certificates according to EN 10204 (Ex DIN 50049) 2.2 on load bearing parts. This conformity document affirms (by the manufacturer) that parts are in compliance with the requirements of the order based on non-specific inspection and testing (i.e. results are typical material properties for these parts.)							
M2 Material traceability certificates according to EN 10204 (Ex DIN 50049) 3.1b on load bearing parts. These documents affirm (by a department independent of the manufacturing department) that the actual parts used in the product are in compliance with the order based on specific inspection and testing (i.e. results are actual material properties for those parts.)							
M3 Material traceability certificates according to EN 10204 (Ex DIN 50049) 3.1b on load bearing parts. These documents affirm (by a department independent of the manufacturing department) that the actual parts used in the product are in compliance with the order based on specific inspection and testing (i.e. results are actual material properties for those parts in a finished, as delivered condition.)							
(5) Not available on Third Generation Series							

Drum lengths		
FA2B & FA2.5A	in.	mm
S	7	178
M	13 1/2	343
L	20	508
R	24	610
FA5A		
S	12	305
L	24	610

Drum lengths available in. (mm)						
Model	8 (203)	12 (305)	16 (406)	24 (610)	30 (762)	36 (914)
FA150KG	yes*	Std	yes*	yes	yes*	yes*
FA2	yes	yes	yes	Std	yes*	yes*
FA2.5	yes	yes	yes	Std	yes	yes
FA5	no	yes	yes	Std	yes	yes

Contact factory for lengths other than shown.
* Special order

- Special optional requirements for offshore compliance are available (see codes above where applicable):
- Material traceability
 - Charpy testing
 - Certificate of compliance
 - Third party witness
 - Customer witness
 - Special documentation
 - Regulatory agency certification
 - Low temperature materials

Man Rider winches have been designed and built to meet the requirements of the Offshore Oil Industry, particularly those specifications of the Norwegian Maritime Directorate, the Norwegian Petroleum Directorate and the UK HSE. They are Type Approved by Lloyds Register of Shipping, Det Norske Veritas (DNV) and the American Bureau of Shipping (ABS). There is no standard covering the use of these Man Riders in other than the offshore environment. It is, therefore, the user's responsibility to determine the suitability of this product for any particular use and to check for compliance with applicable regulations.